

Zodiac CH 640 Information Package

08/15/08



Handling is solid and friendly, as a family cruiser should be... the CH640 handles predictably and lands almost without conscious thought. It appears that Zenair has produced another winner, a worthy addition to the two-seat line that preceded it.

- "A Kit Airplane for the Family," Custom Planes magazine (9/2001)

Designer Chris Heintz introduces new four-seat kit aircraft design

Veteran aircraft designer Chris Heintz introduced his newest light aircraft design, the ZODIAC CH 640, at the EAA Sun 'n Fun fly-in in Lakeland, Florida (April 2001). The new design is a four-place, low-wing, all-metal kit aircraft design.



"My latest design is the result of growing customer demand for a simple yet fully-capable four-seat aircraft," stated Chris Heintz. "While a new design, the four-seater is based primarily on my proven type-certificated CH2000 production aircraft design, and is also influenced by the ZODIAC CH 601 series kit designs and my Zenith CH 300 design from the 70s."



The CH 640 is a conventional four-seater, with a 2 + 2 seating configuration. The prototype aircraft is powered by a 180-hp Lycoming O-360 engine. The design features a fixed tricycle landing gear, large dual gull-wing doors, a wing span of 31.5 feet and an overall length of 23 feet.

Heintz developed the new design in response to demand from kit aircraft builders for an affordable and simple four-seater. While there are literally hundreds of two-seat kit aircraft designs available for construction, there are few modern four-seat designs on the market: The available designs are either complex high-performance planes (such as the Lancair IV) or "utility" designs such as Murphy's Super Rebel and Heintz' own STOL CH 801. The new ZODIAC CH 640 is designed to bridge the gap between these utility designs and the fast and expensive composite designs - to make it a practical and useful aircraft for the "average" pilot/builder. The CH 640 has a useful load of 1,000 lbs., making it a "true" four-seater.

Furthermore, the success of the kit industry has attracted many pilots from the "general aviation" field – pilots seeking the value, choices, and building challenge offered by kit aircraft. The high cost and lack of innovation in general aviation has convinced many pilots to build their own aircraft. Based on a production aircraft, the CH 640 has the handling characteristics that conventional pilots are most familiar with, and even comes with a dual yoke control system instead of the control sticks found in most kit aircraft. The heavier



weight of the aircraft makes it well suited for pilots transitioning from Cessna or Piper aircraft. While the rear seat in most four-seaters is only occasionally occupied, a larger aircraft offers the pilot (and passengers) more space (both elbow room and space for overnight bags) and more stability, especially useful in aircraft operated under IFR. The increased room and payload make the Zodiac CH 640 a true cross-country aircraft, well suited for long cross-country trips.

The kit aircraft industry has matured over the years and many customers are now second or third time builders: *"The CH 640 offers more aircraft to builders – an aircraft that is more than a weekend toy."* Heintz explained. *"Also, many of today's kit customers are demanding more 'utility' in a kit aircraft. Wives are getting more involved in the decision-making process of which airplane to build, as well as being more involved in the building and flying of the aircraft. Obviously, a back seat for the kids and baggage is important."*



Heintz used the Zenith CH2000 as the basic platform for his new design since the aircraft already boasted a huge cabin area, and the type-certificated design could easily be "stretched" into a four-seater. Starting with a basic CH2000 fuselage assembly, the CH 640 started to take shape by "stretching" the cabin area and adding the rear seat. New wings and horizontal tail sections were also developed, and the firewall-forward side was borrowed from the Heintz' STOL CH 801 design which utilizes the same engine.



"Based on the ZENITH CH2000, the new four-seat airframe was really quite simple to build, taking just three months to put together," stated Heintz. The basic flight test program has been completed, and the new design made its first public appearance at the EAA Sun 'n Fun fly-in convention in Lakeland, Florida (April 2001).

While a larger aircraft, the CH 640 kit build-time, complexity and cost is very competitive with most two-seat aircraft designs. The CH 640 is unmistakably a Heintz design – with its conventional all-metal construction adapted for quick and simple kit construction. Kit parts are supplied ready-for-assembly, using blind rivets, which are as easy to set as "Pop" rivets. Many of the kit parts are the same design as the production ZENITH CH2000.

"We're one of the only kit aircraft manufacturers that also has an FAA production certificate," stated Heintz. *"Customers benefit from the quality control program we have in place, while not having to pay the higher cost of a production aircraft."* The standard kit is estimated to require 1,500 assembly hours, a figure that compares very favorably with many two-seat kits on the market today.



Quick-Build Kit: The manufacturing and aircraft assembly experience of Zenair makes it logical for the company to offer quick-build kits for the CH 640 design, since it already assembles the CH2000 / Alarus production aircraft at its facilities. The company is offering Quick-Build kits of the Zodiac CH 640, which drastically reduces kit building time and complexity.

DESIGN AND CONSTRUCTION

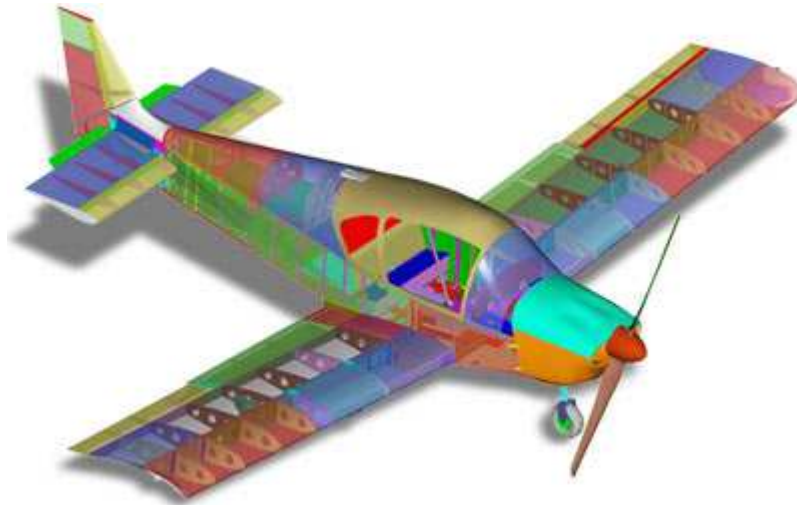

The ZODIAC CH 640 four-seat kit aircraft is based in large part on Chris Heintz' ZENITH CH2000 aircraft design, a versatile two-seat production aircraft. The modern design makes use of advanced technologies, while using proven design concepts and simple systems for easy assembly and maintenance. Developed for the first-time builder and demanding recreational pilot, the CH 640 has been developed to be easy to build and to maximize flight performance and efficiency.



Based on the Type-Certificated Alarus CH2000:

While most production aircraft are relatively complicated and would not be well suited for construction by amateurs, the CH2000 aircraft was designed to be the least-expensive type-certified aircraft. To achieve this design Chris Heintz made the aircraft parts and assemblies simple by drawing on his extensive experience producing kit aircraft for first-time builders. This simplicity has made the aircraft not only easy and affordable to build, but also easy to maintain and has kept the cost of replacement parts lower than originally thought possible.

"[Chris Heintz] designs have earned an excellent reputation among pilots, builders, and aviation authorities for their durable all-metal construction, normal flight characteristics, reliability, and low maintenance."

- EAA Sport Aviation magazine, December 1999.



The CH2000 aircraft was certified by the Federal Aviation Administration (FAA) on July 31, 1994 with the issuance of Type Certificate No. TA5CH. The CH2000, as presently produced, is approved for spins, and when configured with the appropriate option package, is certified for IFR operation.

Certified in the Utility Category (+4.4 / -2.2 g at max. gross weight), the aircraft was designed with a design safety factor of two, compared to 1.5 for standard FAR 23 certified aircraft. The extra safety factor gives the aircraft +8.8/-4.4G ultimate load factor. Recently, the CH2000 was the first aircraft to be fully approved by the new European Certification Committee, certifying the aircraft in all European countries simultaneously.

The CH2000 airframe has no "life time limit" since it has been proven that if an aircraft is designed by using classic construction methods and materials, and if the design safety margin is 2, it will not fatigue appreciably during its projected lifetime.

While a two-seater, the CH2000 design features a large cabin and easy-access dual gull-wing doors. The ZODIAC CH 640 features a redesigned cabin with the addition of rear seats, a larger wing and stabilator were designed for the additional load requirements of the four-seat ZODIAC CH 640.

The ZODIAC CH 640 aircraft is built of stressed-skin semi-monocoque all-metal construction, just like today's factory-built planes, but adapted specifically for the kit builder. Sheet-metal construction is outstandingly the most widely used aircraft building method around the world, and has proven itself as the ideal aircraft material since the early pioneering days of aviation.

The simple stressed-skin semi-monocoque construction of the ZODIAC CH 640 uses single curvature sheet-metal skins riveted to internal structural members.

The sheet-metal skins, main wing spar, structural ribs, longerons, stiffeners and bulkheads are fastened together with Zenith's proven riveting method using blind rivets, which are as easy to set as 'pop' rivets, requiring only a simple hand rivet puller. The corrosion-resistant rivets provide a permanent structural bond and tight low-profile dome finish, formed by the custom riveter head. The rivet stem becomes locked in after being set to provide a water-tight seal. The 1/8-inch and 5/32-inch Avex rivets used are very sturdy and durable fasteners, and may be used over a wide grip area. The blind rivets are much easier and quicker to set than bucked rivets, and don't require the use of a noisy pneumatic rivet hammer or counter-sunk rivet holes.

The primary structure, with the exception of the steel tube engine mount, steel nose gear strut, and other selected parts, is of 6061-T6 aluminum sheet metal riveted to aluminum extrusions with Avex rivets. This blind rivet, manufactured by Textron's Avdel division, is similar to the traditional "Cherry" rivets except that they can be pulled with any standard blind rivet gun. Major structural items such as the wing spar and landing gear fuselage support are solid riveted at the factory with standard

control hardware are the AN/MS type. Some composites are used on non-structural fairings such as the engine cowling and wing tips.

Simple systems, modern materials, and design ingenuity minimize required maintenance, and make the ZODIAC CH 640 simple to build and fly, affordable, and very durable... an aircraft you'll be proud to own and fly for many years.

While the ZODIAC CH 640 design is new, the simple construction techniques that have made the Heintz designs famous have remained the same.

Construction of the CH 640 kit aircraft is 'modular' – each section of the aircraft is built separately on a workbench. Many builders thus choose to buy 'component kits,' purchasing kit sections as they progress through the project. The modular construction of the kit means that required workshop space is minimal – most builders construct the kit in a single-car garage or basement workshop.

Once all the airframe sections have been assembled, the wing and tail sections are bolted to the fuselage and the landing gear, controls, and fuel system are installed.

The aircraft was designed with extra large maintenance access panels in the wings, and fuselage. Under the rear fuselage, there is a huge 2x2 feet square access panel, which gives easy access to the control cables, and flap motor.



NOTE: While the ZODIAC CH 640 design is based on the Zenith CH2000 type-certificated aircraft, the ZODIAC CH 640 design and kit is not certified, certificated or approved by the FAA. The ZODIAC CH 640 is being offered as a kit, to be constructed by the owner as an amateur-built "experimental" aircraft.

PERFORMANCE Lycoming O-360, 180-hp	Load: 518 Lbs Take-Off Weight: 1, 718 Lbs.		Gross Weight 2,200 Lbs.	
MAX LEVEL SPEED	167 MPH	267 km/h	157 MPH	251 km/h
CRUISE SPEED (75% power @ 7,000 Ft.)	154 MPH	246 km/h	150 MPH	240 km/h
STALL SPEED (Flaps Down)	40 MPH	65 km/h	47 MPH	76 km/h
STALL SPEED (Flaps Up)	50 MPH	81 km/h	58 MPH	93 km/h
RATE OF CLIMB	1,400 FPM	7.0 m/s	950 FPM	4.8 m/s
SERVICE CEILING	16,000+ Ft.	4880+ m.	12,800 Ft.	3,900 m.
ENDURANCE (Standard)	3 Hrs. 45 min.		3 Hrs. 45 min.	
RANGE (Standard)	525 Miles	845 km.	510 Miles	820 km.
TAKE-OFF ROLL	950 Ft.	260 m.	990 Ft.	300 m.
LANDING ROLL	800 Ft.	244 m.	1,150 Ft.	350 m.

Above performance figures with the Lycoming O-360 engine (180 BHP: 390 lbs. with accessories and basic fixed-pitch Sensenich 76-EM8-0-63 metal propeller). Standard atmosphere, sea level, no wind. All technical data, specification and performance figures subject to change without notice. Endurance and range figures without fuel reserve. Contact ZENAIR for additional performance figures and flight test reports.

DESIGN LIMITATIONS:

POWER (min./max.)	150 - 240 BHP.	
MAX. INSTALLED POWERPLANT WEIGHT	440 lbs.	200 kg.
MAXIMUM TAKE-OFF WEIGHT (MTOW)	2,200 lbs.	1000 kg.
DESIGN LOAD FACTOR (ultimate) @ 2,200 lbs.	+ 5.7, - 2.9	
MAX. WING LOADING (@ 2,200 lbs.)	14.6 PSF	71.4 kg/m ²
MAX. FLAP EXTENDED SPEED	115 MPH	185 km/h
MAX. CRUISE SPEED - VC	160 MPH	256 km/h
NEVER EXCEED SPEED (VNE)	175 MPH	280 km/h

* Basic empty weight: Prototype aircraft equipped with the Lycoming O-360 (with 60 amp alternator, starter, Gill 35 battery, seats with upholstery, 600 x 6 main wheels with dual caliper brakes, 500 x 5 nosewheel, wheel fairing, metal fixed pitch propeller, complete night flight package (lighting system), and instrument gyros, and advanced avionics Garmin package. Other installed equipment will effect empty weight of the aircraft. Technical data, specification and performance figures subject to change without notice.

SPECIFICATIONS	ZODIAC CH 640	
LENGTH	23 Ft.	7.01 m.
HEIGHT	7 Ft. 4 In.	2.25 m.
WING SPAN	31 Ft. 6 In.	9.6 m.
WING AREA	150 SQ.FT.	14 m.sq.
WING CHORD	4 Ft. 9.5 In.	1.46 m.
HORIZONTAL TAIL SPAN	9 Ft. 10 In.	3.0 m.
HORIZONTAL TAIL AREA	30 SQ.FT.	2.8 m.sq..
EMPTY WEIGHT*	1,147 LBS.	545 kg.
DESIGN GROSS WEIGHT	2,200 LBS.	1000 kg.
USEFUL LOAD	1,053 LBS.	454 kg.
FUEL CAPACITY (Standard) - Fuel weight (Standard)	38 Gal. (2 x 19) = 230 LBS.	144 l. (2 x 72) = 104 kg.
FUEL CAPACITY (Extended Range Option) - Fuel weight (Extended Range Option)	46 Gal. (2 x 23) = 275 LBS.	174 l. (2 x 87) = 125 kg.
DESIGN PAYLOAD - Occupants + Baggage / Cargo	823 LBS. = 4 X 205 lbs.	360 kg. = 4 X 90 kg.
WING LOADING	14.6 LBS/FT ²	71.4 kg/m ²
POWER LOADING	12.2 LBS/BHP	5.55 kg/BHP
CABIN WIDTH	46 INCHES	117 cm.
CABIN LENGTH (rear seat back to rudder pedals)	74 INCHES	188 cm.

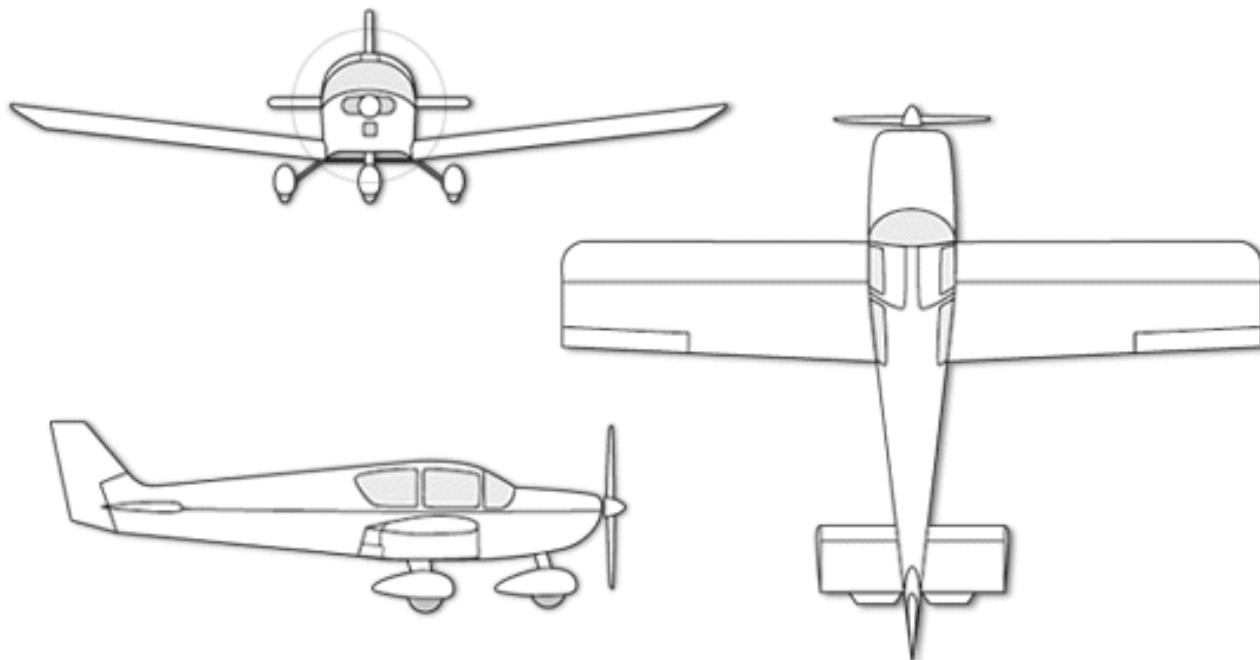



Engine Mount. The engine is attached to a dynafocal engine mount. The engine mount is made up of 4130N Tubing $\frac{3}{4}$ " diameter with a wall thickness of .058" The dynafocal rubber mounts are standard off-the-shelf parts. The engine mount does not support any part of the nose wheel assembly.

Baffles. The engine baffles are simple and made from standard aluminum stock. They are easy to replace and are independent of the engine cowling. Standard baffle tape is riveted to the baffles to seal airflow through the cowling.

Engine Cowling. The engine is surrounded by a top and lower cowl. It is one of the few parts on the aircraft which is made of fiberglass. Less than 15 screws hold both cowls together and to the firewall. A large oil access door is located on the top right of the cowl giving adequate room for oil checks. The opening at the front of the cowling is extremely large but very effective in keeping the engine cool on hot summer days.

The exhaust system is constructed of stainless steel and incorporates dual mufflers with optional heater shrouds to supply heated air for the cabin, windshield defroster, and the carburetor de-icing system. Two separate mufflers make it easy and inexpensive to maintain. They are made of 321 type stainless steel with .035" wall thickness. The engine noise is less than 72 dB qualifying it for European noise regulations. The cabin heat shroud is around the left muffler and the carburetor shroud is around the right. The cabin heat shroud is easy to remove for muffler inspection.

The carburetor air intake box uses a standard Bracket air filter. The air intake box to the carburetor is steel and the rest is aluminum. The engine cowling is not attached to the intake box, making it easy to remove the cowl.

The new Lycoming engines are supplied with dual Slick magnetos. These new style magnetos only weigh 3-3/4 pounds each, and they are completely re-buildable with many up-grade kits available on the market.

The new SkyTech starter motor is also supplied with the factory-new engine. This is one of the newest starters on the market today, and is factory-installed by Textron Lycoming. It weighs less than half of the old type and increases the turnover rate of the propeller for better starting.

The alternator output is 70 Amps, which is more than enough for a full IFR avionics package including the standard night light package. It is factory- installed by Textron Lycoming, and is reliable and extremely easy to maintain.

The voltage regulator can be adjusted without removing the unit from the firewall.

The oil cooler is mounted on the firewall and not on the engine baffles. The engine is equipped with a thermal bypass valve for colder weather, by-passing the oil cooler. In freezing weather a winter baffle can be added. The winter baffles can be installed and removed by simply removing the cowling and by installing less than 10 screws in the existing baffles and not the engine.

The Sensenich 76-EM8-0-62 fixed pitch propeller is all-aluminum, easy to maintain, and easy to replace and install. A Sensenich aluminum spinner is also available. It is held in place with 8 screws and if the spinner is removed, will not change engine cooling or performance of the aircraft.

The oil filter is an off-the-shelf item and is easy to replace and install. No parts have to be removed in order to service the oil filter. It is installed and approved by Textron Lycoming.



LYCOMING ENGINE

Over the past 65 years, Lycoming has produced more than 260,000 piston aircraft engines. With a reputation for performance and reliability, Lycoming piston engines power more than 85% of the new general aviation aircraft produced worldwide, including Chris Heintz' ZENITH CH2000 two-seat design.

Whether you buy a factory-new, remanufactured or overhauled engine, Lycoming engines provide a history of performance and reliability, with worldwide parts and warranty support from Textron Lycoming.



The popular Lycoming O-360 (180-hp) engine is the standard powerplant for the ZODIAC CH 640, with a full firewall-forward installation kit available.

ENGINE CONTROLS



Engine controls consist of a throttle, a mixture, and a carburetor heat "push pull" control. These controls are located at the lower center of the instrument panel where they are accessible to both pilot and co-pilot.

The black handled throttle control is used to adjust engine RPM. Springs are added to the throttle lever arm to ensure that the engine will go to full power if linkages should fail.

The red handled mixture control is used to adjust the air-to-fuel ratio in the carburetor. The engine is shut down by pulling the mixture control to the full lean position. In addition, the mixture control has a push button lock to prevent inadvertent activation of the mixture control.

The blue-dotted carburetor heat control has two positions: pull out for 'ON', push in for 'OFF' The key switch is a standard aircraft type with the following positions: OFF, LEFT MAG, RIGHT MAG, ON, START. Overturning of the engine will blow the main master breaker before damaging the starter.

There are no cowl flaps or other special engine controls.

THE KIT

The underlying philosophy behind the ZODIAC CH 640 kit is to provide the builder with everything needed to complete the airframe - with only basic tools and skills. Drawing upon Zenair's 25 year kit aircraft manufacturing and design experience, the kit is developed for maximum ease of construction, while using only materials and parts of the highest quality. The ZODIAC CH 640 kit is estimated to require only about 1,500 hours to build from the complete factory-supplied kit.

All you'll need to get started is a level workbench and basic hand tools. The detailed and illustrated photo manuals guide the builder through the entire kit assembly process following a logical **step-by-step sequence**. All kit components, parts and hardware are supplied – labeled and numbered for easy identification. Every airframe bolt, fastener, and rivet is supplied with the standard kit.



The airframe kit takes straight-forward and basic assembly work to put together using only simple tools, such as an electric hand drill, a hand rivet puller, 'Cleco' temporary fasteners, a set of wrenches, a few hand files, sheet-metal snips, etc. Importantly, virtually no jigs and fixtures are needed in the building process, as all sections are built up from the flat workbench. A bending brake, shear or other machinery is not needed, and assembly is easily done in a single car garage or basement workshop.



- **BASIC HAND TOOLS:** Tape Measure, Electric Hand Drill, Hand Rivet Puller, Cleco Temporary Fasteners, Sheet Metal Snips, Hand Files, etc.

While previous aircraft building experience and sheet-metal skills are always an asset, the ZODIAC CH 640 kit and assembly instructions are developed specifically for the inexperienced novice builder. The simplicity of construction, quality of parts and components, and the completeness of the kit translates into low build-times and a very high kit completion ratio, even for novice builders.

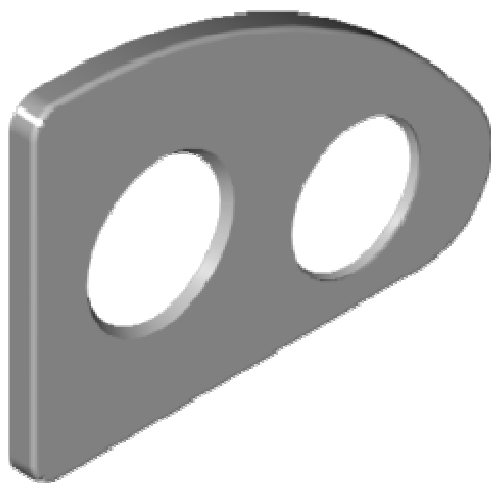

The ZODIAC CH 640 kits will meet the requirements for amateur-built (experimental) categories in the United States and Canada, as well as in most countries around the world. In the kit, all the wing ribs and fuselage bulkheads will be supplied pre-formed. For example, the internal wing ribs are first press-formed, with lightening holes cut and flanged, and then hand finished at the factory for a perfect ready-to-install fit. The heavy-duty wing spars come complete with all solid (bucked) rivets already set by factory professionals. Surface skins - wings, ailerons, elevator, rudder, and fuselage - are ready for fitting.

Pre-assembled parts (such as the wing spar) are factory-treated with zinc-chromate primer for maximum corrosion resistance. Welded parts, such as the engine mount, control assemblies, and fuel tank, will come factory welded and ready to install.

The ZODIAC CH 640 kit is complete: the heavy-duty landing gear system, hydraulic brake system, fiberglass wing tips, control systems, welded aluminum fuel tanks, etc., are standard equipment in the complete airframe kit.



The ZODIAC builder is able to start assembly right away after taking delivery of the kit. Working from a flat table, the builder can immediately begin assembly - simply by measuring, drilling and riveting, and thus progress through the whole airframe section by section, aided by the detailed step-by-step manuals and visual photo guides supplied with the kit. Building the all-metal CH 640 is straight forward, requiring no complex jigs, and no messy (and hazardous) doping or epoxy work is involved. With the proven and simple all-metal construction technique, the ZODIAC builder does not have to worry about having a temperature controlled dust-free work-shop environment, and does not have to mix compounds and wait for parts to cure.

A new aircraft design and kit, the ZODIAC CH 640 kit and its assembly processes are completely new, yet draw on Zenair's extensive aircraft manufacturing expertise. Assembly of the kit does not rely on static blueprints, but makes extensive use of a very comprehensive series of step-by-step photo manuals with hundreds of very detailed photos with brief text instructions. Digital photo and video technology has allowed us to capture all the building steps in minute detail, with the ability to reproduce the high-resolution images in simple and logical step-by-step manuals.

The canopy kit is supplied as a "ready-to-install" component. The windshield and the dual gull-wing doors are already fitted to the molded fiberglass assembly - the whole canopy assembly being ready to simply place on top of the fuselage assembly.

Assembly of the kit is divided into many small modular projects, allowing the builder to focus on one small section at the time before moving on to the next. For instance, the wing is divided into numerous sub-sections. This modular sequential approach minimizes required workspace, and also allows builders to buy the kit sections as they progress through the project.



QUICK-BUILD KIT



The manufacturing and aircraft assembly experience of Zenair makes it logical for the company to offer quick-build kits for the CH 640 design, since it already assembles the CH2000 production aircraft at its facilities. The company is offering Quick-Build kits for the Zodiac CH 640, which drastically reduce kit building time and complexity. These kits are made and assembled at the Zenair factory using many of the same jigs and procedures for the CH 2000 certified production aircraft.



Designer Chris Heintz' extensive light aircraft engineering experience has allowed the development of an aircraft that minimizes the actual number of parts in the aircraft (thus saving the builder cost and assembly labor) and Zenair's comprehensive aircraft manufacturing experience and capability allows us to do factory sub-assemblies and components for the basic kit parts. Our basic philosophy with the kit is to provide all the parts and components ready for assembly, so that they require only basic skills and tools to be put together.

If an assembly requires a special jig or critical measurements, the assembly is pre-jigged or built at the factory or supplied with the jig with the kit. Critical and time-consuming assemblies, such as the control systems, are completed at the factory and supplied ready for final assembly.

Customers will find the ZODIAC CH 640 kit to be easy and enjoyable to build, even for novice first-timers, and it should take less time to put together than most two-seat kit aircraft on the market.

The Federal Aviation Administration (FAA) completed evaluation of the Zodiac CH 640 kit on May 2, 2001 and determined that the quick build kit, as evaluated, met the intent of Code 14 of Federal Regulations (CFR) Part 21, Section 21.191(g). The FAA noted that the evaluation should not be construed as meaning the kit is FAA certified, certificated or approved, but is eligible for airworthiness certification by amateur builders.

“The most complete FAA 49%-51% approved kit on the market. The CH 640 Quick Built kit”

This kit comes with the following completed assemblies:

WINGS - Wings are complete up to the end of the main spar. The main spar is complete, the ribs are riveted to the spar, bottom skins are riveted to the spar and ribs, including the bottom of the nose skin. The aileron bell-crank is installed and riveted. The top skins have been fitted and drilled. Ailerons are complete. One side has been left open for inspection and must be riveted. Same for Flaps. - *Customer must add a 20 inch spar extension to the main wing section, and the fuel tanks must be added, in order to complete the wings*

TAIL - Includes electric trim tab kit and fiberglass fairing tips. The Stabilator is complete. One side has been left open for inspection. *Customer must assembly the rudder. This is the only aircraft section that must be completely assembled by the customer*

FUSELAGE - The main fuselage is complete, as shown in the photo's. Side skins are riveted to the floor, firewall, and tail frame. Rear bulkheads are installed, including top skins but not riveted. *Customer must install the rear and front seats, rivet the rear top skins, install the instrument panel and other small items.*

GEARS & WHEELS - Includes wheels with hydraulic disk brakes. Landing gear is ready to be installed. *Customer must drill out the axel holes in the gear, install the axles and wheels, and fit the assembly to the fuselage. Nose gear bearings are already in place on the firewall.*

CABIN / CANOPY - The fiber glass canopy is one large piece, ready to be installed. *Customer must install the canopy to the fuselage. Windshield must be glued to the canopy*

CONTROLS - Control items are ready for installation. *Customer must install the control wheels, control cables, and other small items to the fuselage.*

FUEL SYSTEM - *The customer must install the wing tanks in the wings before closing the wing skins. Fuel lines, gas-collator, selector switch and other fuel items must be installed*



Quality Aircraft Since 1974

Zenair Ltd. is an international company in modern production facilities located at the Huronia Airport, Midland Ontario Canada, just 60 miles North of Toronto. **The company was established in 1974** and up to 1996, Zenair manufactured both aircraft kits, and factory-assembled advanced ultra-light aircraft (similar to the FAA proposed Sport Plane Category). Zenair presently manufactures parts and assemblies for the CH2000 aircraft and kits for the Zodiac CH 640. With more than 25 years experience, Zenair is recognized as a pioneer in the sport aircraft industry in designing, developing, manufacturing and marketing light aircraft.

Over 3,000 customers in more than 50 countries, Zenair has been a leading player in the growing kit and sport aircraft industries in both domestic and international markets. The Zenair design has developed an excellent reputation and has earned the *NASAD Seal of Approval*.

Mr. Chris Heintz, president and founder of Zenair Ltd. is an accomplished aeronautical engineer. He is a graduate of the E.T.H Institute in Switzerland and served in the Air Force. Mr. Heintz worked for Aerospatiale on the supersonic Concorde jetliner, and later became chief engineer at Avions Robin (France) where he designed several fully certified two and four seat production aircraft to FAR 23 standards.

Through the years, Mr. Heintz has introduced more than 16 successful aircraft, and over 1,600 Chris Heintz designs are presently flying around the world. The Heintz designs have earned an excellent reputation among pilots, builders, the press, and aviation authorities for their durable all-metal construction, normal flight characteristics, reliability, and low maintenance requirements. With a career-long dedication to aviation, Chris Heintz is a past recipient of the Dr. August Raspert Memorial Award *"for outstanding contribution to the advancement of the design of light aircraft,"* and his designs have been honored with numerous awards worldwide. In 1995 the Federation Aéronautique Internationale (FAI), awarded Chris with the prestigious Honorary Group Diploma for *"greatly contributing to the progress of aviation"* and he was inducted into the prestigious EAA "Hall of Fame" in 1999.

In 1994, Chris Heintz obtained FAA type-certification for the CH2000. The all-purpose production aircraft has become a popular trainer with flight schools and low time pilots.

Zenair is committed to the advancement of sport aviation industry. Zenair is a member and supporter of the Sport Aircraft Manufacturers Association (SAMA), UAA, LAMAC, EAA, RAAC, AOPA, COPA, LAMA, NATA and NASAD, and has been consistently recognised for its contribution to the industry.

"While the CH2000 is still considered a new aircraft, it's been certified by the FAA now for six years: These six years have given us the opportunity to perfect the aircraft - the production of the aircraft as well as the features sought out by our customers," explained Heintz. "Furthermore, these past few years have definitely indicated to us that there is a strong market for a basic, yet fully capable aircraft, such as the CH2000. This aircraft was the valid basis for extrapolation into the four seat CH 640".

Zenair Ltd. plans to certify the new Zodiac CH 640 with Transport Canada and the FAA to FAR23, where the process is expected to take up to 5 years. Build your own aircraft now and save.



Add the latest avionics to your aircraft, such the advance digital HSI from Sandel and Garmin GPS/COM/NAV.



Ordering Procedure:

To order your CH 640 kit, fill-in the Order Form, and return to Zenair Ltd with your deposit. On kit orders, a 50% deposit is required with the order. For orders totaling less than \$1,000.00, send full payment with the order. When we receive your order, a Zenair Ltd representative will then contact you to provide you with a scheduled shipping date, and to arrange shipping or pick-up details. The balance for the order will be due prior to shipping or upon pick-up. Kit orders can be either crated and shipped to you, or picked up at the factory.

For all prices, please see www.zenair.com

Picking-up your kit from the Zenair Ltd. factory:

Rather than having the aircraft kit crated and shipped to you, you may opt to drive to the Zenair Ltd factory to pick-up you kit (saving the crating and shipping charges), while also giving you the opportunity to visit the factory and go up for a demo flight in a factory demo aircraft.

The complete kit, or section kits, may be picked-up at the Zenair Ltd. Factory in Midland Ontario Canada. Typically, you can pack the complete kit in either a full-size pickup truck, full size van , or in a 12-foot enclosed trailer, such as a "U-Haul" rental trailer. The typical weight of the airframe kit is about 400 lbs. The longest parts are 12 feet long. The composite canopy is the largest.

When you pick-up a kit, we do not package (crate) the kit parts so that you can easily and efficiently load the parts in your vehicle. As you are not charged for crating or packaging, please bring packing materials with you to properly load and secure the parts. We recommend you bring moving blankets and corrugated cardboard to protect the parts as you load them, as well as rope and cardboard packing material. If you use an open pickup truck or trailer, bring a large "tarp" to protect kit from rain, road salt, etc. Depending on the size of the vehicle / trailer, you may need a roof rack to load longer parts, such as the wing spars.

Before making travel arrangements, confirm the pick-up date with Zenair Ltd., as an appointment is required (during regular business hours, unless arranged otherwise). Also, inform us ahead of time of the vehicle and packing materials you plan on bringing, so that we may give you any additional recommendations.

LOADING THE KIT IS YOUR RESPONSIBILITY: You will be responsible for loading and properly packing the kit parts in your vehicle, although Zenair Ltd. staff will be available to lend you a hand in loading. Zenair Ltd is not responsible for parts that may be damaged or lost in loading, transit, or unloading of the kit parts.

Shipping your kit from Zenair Ltd:

Most kits are crated and shipped by surface freight to our customers. Crating and shipping charges are not included in the kit prices. All kit prices are F.O.B. Factory. Unless otherwise specifically arranged Zenair Ltd., all shipments are sent freight collect.

When a crated kit order is sent to you, be prepared to take delivery of the kit. Complete kit orders are usually shipped in a single large crate. Make arrangements to be able to unload the crate and have covered space to place the crate until you unpack it.

International Customer's:

We have extensive experience shipping our kits around the world. We can make arrangements to have the kit delivered to your door (where available) or we can work with your broker or shipper of choice

<u>Sending your order to Zenair Ltd:</u>		
Fax	1-705-526-8022	Fax ORDER FORM with credit card information or request for invoice. VISA only
Mail	Zenair Ltd Huronia Airport P.O. Box 235 Midland Ontario, L4R 4K8 Canada	Mail or courier printed forms with check payment or credit card information.
Email	info@newplane.com	Email inquiries or requests for invoice. Orders cannot be accepted by email at this time.
Telephone	1-705-526-2871 Monday - Friday 8 - 5, Eastern Time	Call with credit card orders or for additional information.

Completing the Purchase Order:

1. **INFORMATION ABOUT YOU:** Clearly print or type your name, mailing address and telephone numbers. If the shipping address is different than the mailing address, make sure to include both addresses.
2. **YOUR ORDER:** Clearly itemize the kit, options and items of your order, with current pricing information. If you are not sure about pricing, fax your Purchase Order to Zenair for a quote.
3. **DETAILS:** Specify any special shipping or pick-up information we need to know.
4. **PAYMENT:** enclose 50% deposit. Make check payable to Zenair Ltd. Contact Zenair Ltd. for bank wire transfers or other forms of payment.
5. **CONDITIONS of SALE and WARNING NOTICE:** Sign and validate conditions of sale and warning notice.
6. **MAIL:** Make copies for yourself and mail the original Purchase Order and Conditions of Sale and Warning Notice. Make sure that they are both signed. Mail together with your payment.

When we receive your order, we will contact you to confirm receipt of your order, provide you with a scheduled delivery date, and make any required shipping / pick-up arrangements.

Builders update:



John Balogh's CH 640 aircraft, featured in EAA Sport Aviation magazine (January 2007):

"The building was enjoyable and challenging but not as difficult as I had thought it would be. The airplane flew pretty much as advertised right from the beginning..."

"It is powered by a Lycoming O-360 with light speed ignition and a fixed-pitch propeller."



Steve Adams' recently completed CH 640:

"I have about 60 hours on it now and couldn't be happier."



JEFF PADEN's beautiful 640. Jeff has an excellent web site documenting the building process.

See <http://www.madbbs.com/~jpaden/>



Quality Aircraft Since 1974. ZENAIR LTD
TEL:(705) 526-2871 - FAX:(705) 526-8022 www.zenair.com