



*Quality aircraft since 1974*

## **SERVICE LETTER September 20-02**

### **Issue Date**

Thursday, September 19, 2002

### **Subject/Purpose**

This Service Letter is for adding OPTIONAL fuel primers to the engine cylinders.

### **Affected Models**

The affected models are aircraft CH 2000 serial numbers 20-0002 and up.

### **Compliance Time**

Non

### **Inspection**

As required

### **Required Parts from one cylinder primer to four**

Part Number	Description	Qty
20-M-38-3	Fuel primer Atomizer with nut and inside sleeve	4
20-M-38-1	Fuel primer bracket	3
91-546	Fuel primer 3/16 I.D. rubber hose	3
64-2	Tee fitting with nut and inside sleeve	3
1/8CL	1/8 copper line	8 feet

### **Action**

- Install fuel primer Atomizers to cylinders.
- Install the fuel primer 3/16 I.D. rubber hose into the fuel primer brackets
- Install fuel primer brackets 20-M-38-1 to cylinders. Drill holes and trim as required.
- Cut and install 1/8 copper lines to Atomizer and "T" fittings
- Install all above items as per schematics on page two and three.
- Note that the Atomizers and "T" fittings are "brass Compression Fittings" and use standard type 1/8 brass Sleeves (#60-2) for 1/8" copper line.

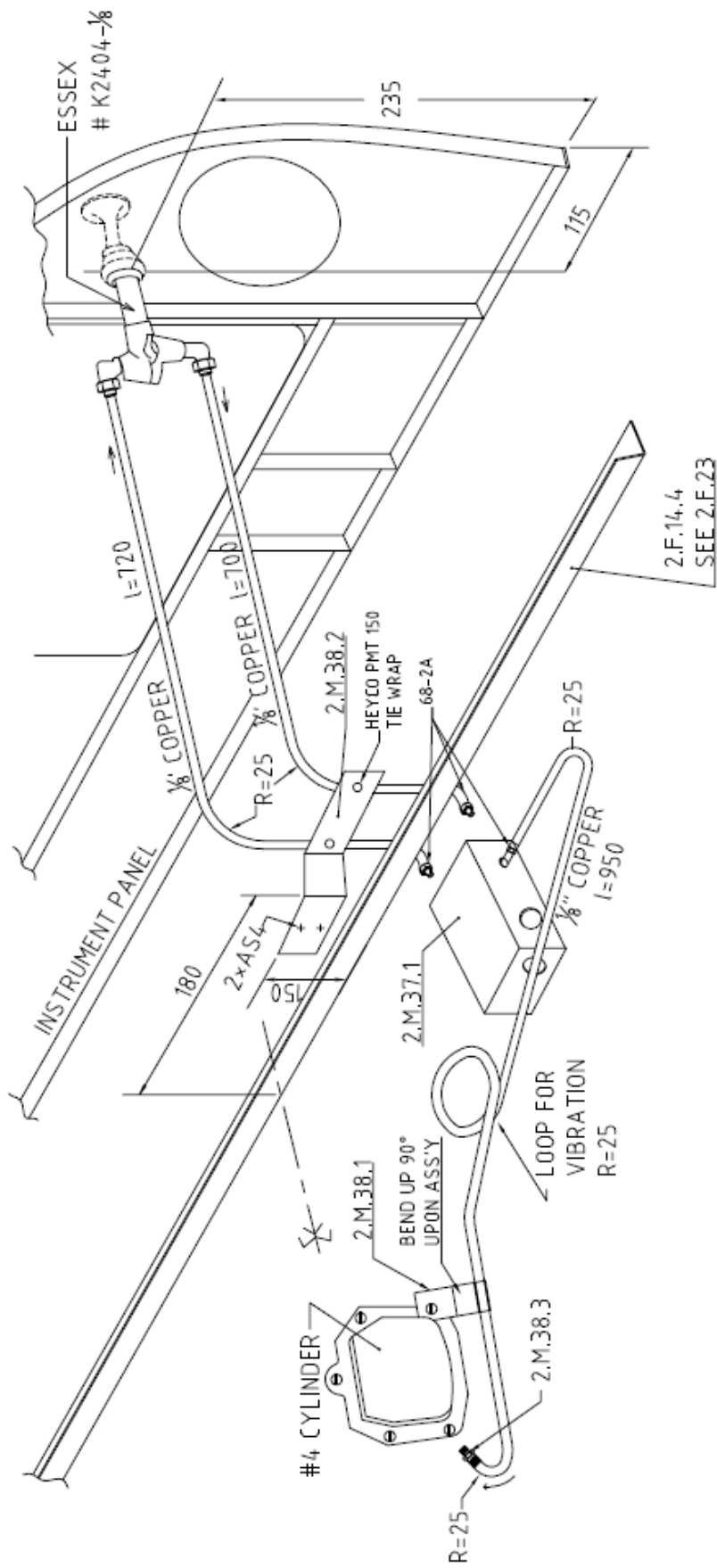

OPTIONAL 4 CYLINDER PRIMER

(VIEWED FROM ABOVE)

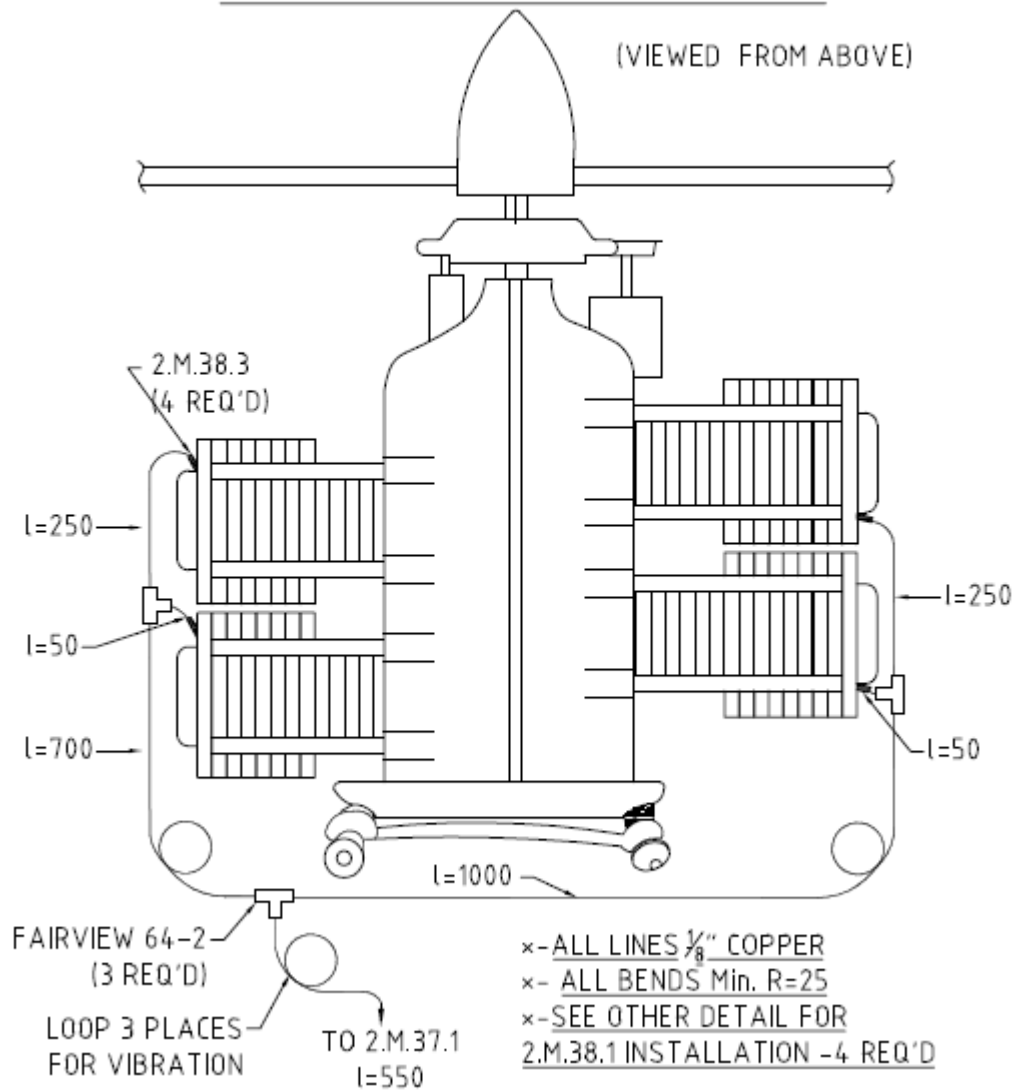

For additional information contact Zenair Ltd.

**ZENAIR LTD, HURONIA AIRPORT, MIDLAND, ONTARIO, CANADA L4R 4K8**  
**TEL:(705) 526-2871 - FAX:(705)526-8022**