



Quality aircraft since 1974

SERVICE LETTER - June 06 2016

Issue Date

June 06, 2016

Subject/Purpose

Assembly details of the CH2000 firewall & nose gear system.

Affected Models

All

Compliance Time

None

Maintenance

As per AC 43.13 and CH2000 Service Manual. Also see Zenair Service Letter of August 2015.

Required Parts

As required

Inspection Frequency

As required

Subject/Purpose

If nose gear and firewall area parts are to be replaced due to a hard landing, the following is to assist in the installation of new parts.

General info

Page drawing shows:

A5. This means the Zenair aluminum rivet A-5 (5/32" dia)

AS5. This means the Zenair stainless steel rivet AS-5 (5/32" dia)

AF5. This means the Zenair aluminum rivet AF-5 (5/32" dia) flush (countersunk once installed).

P30 or P40. This means approximate a distance between the rivets. P30 is 30mm between each rivet. P40 is 40mm between each rivet etc.

Rivet gun. Use the Zenair rivet gun with special heads (#HP-A5) as shown in the CH2000 Service Manual Section 4.1.

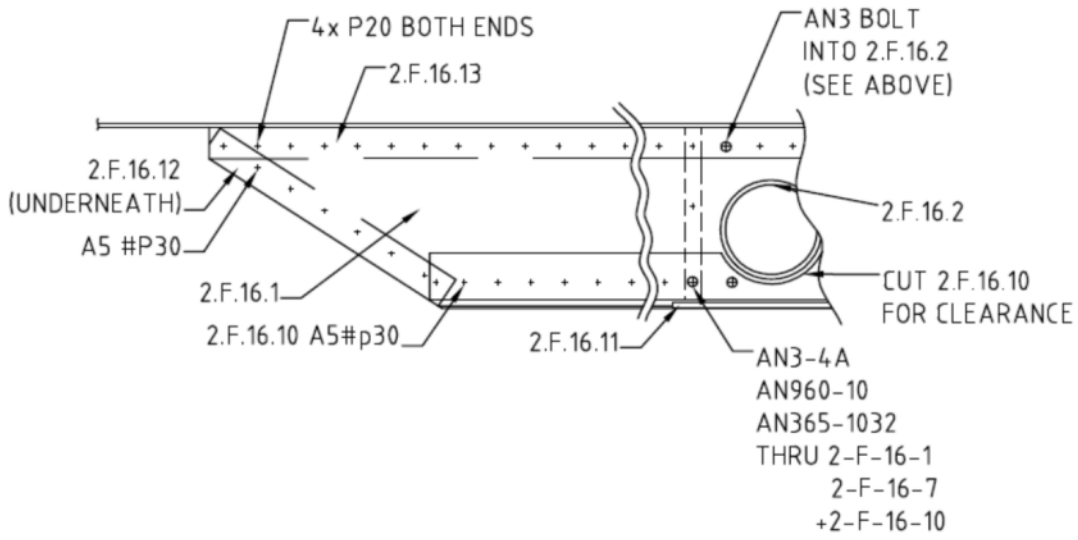
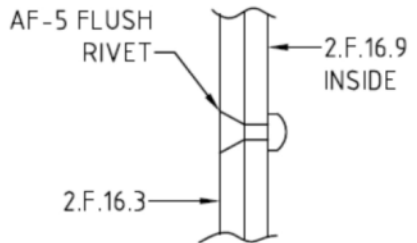
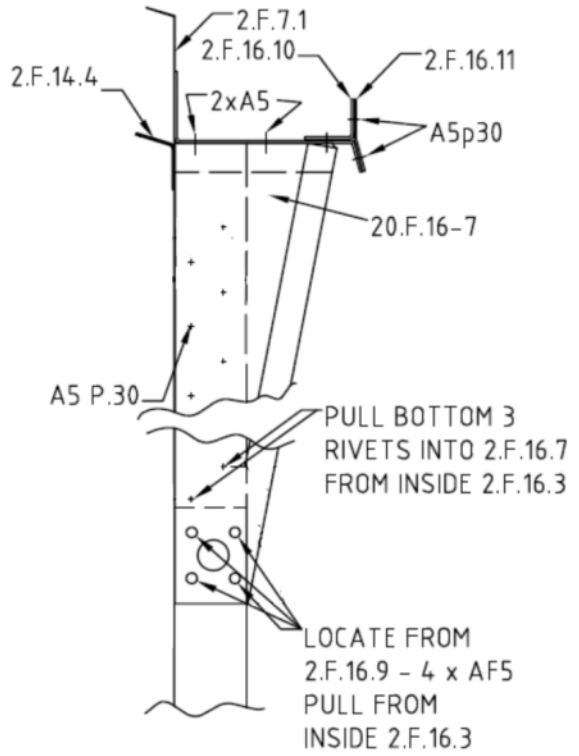
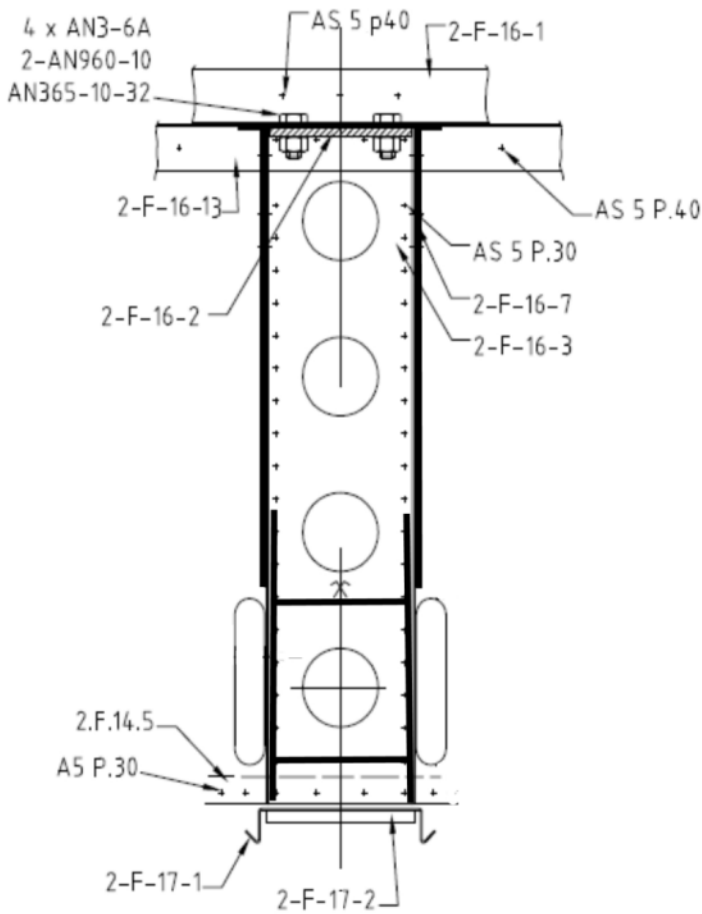

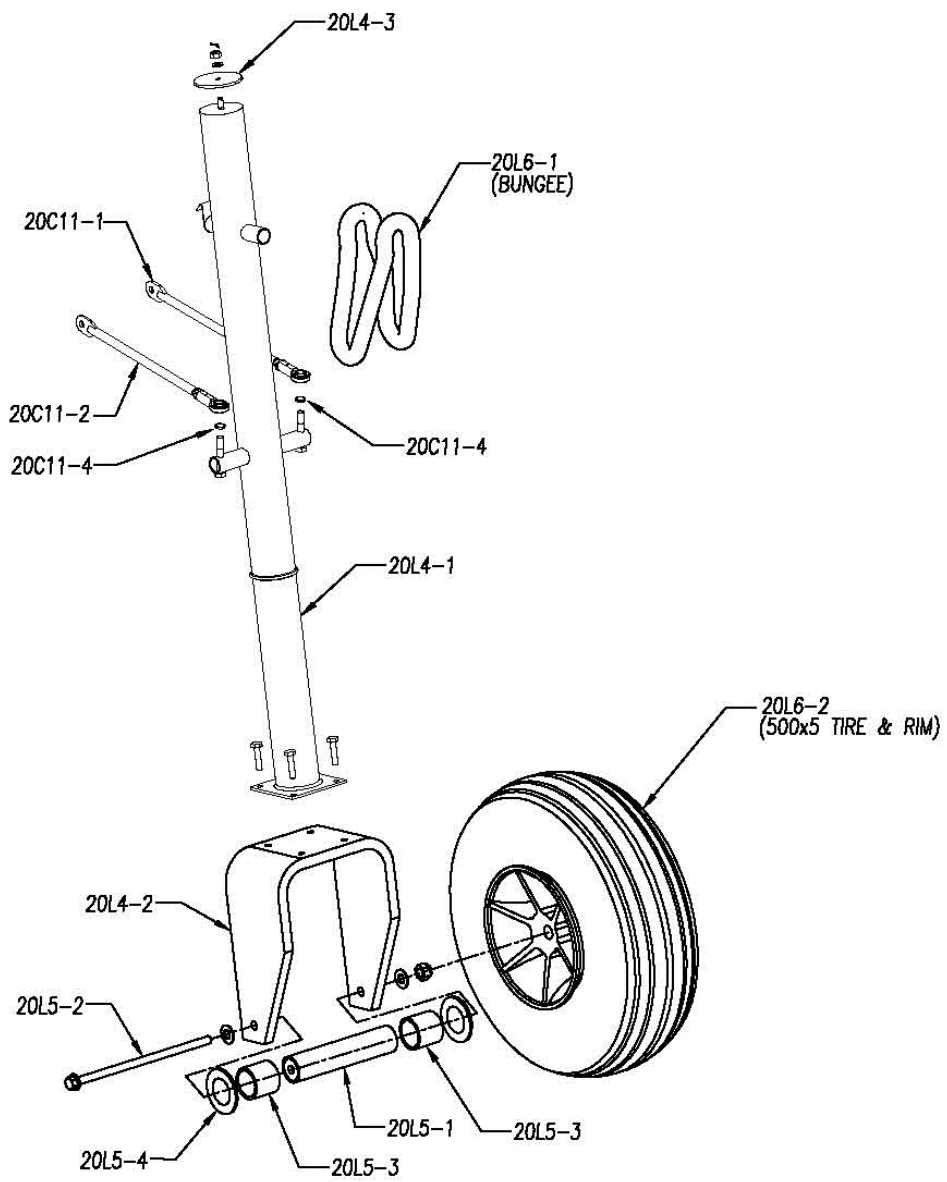

NOSE GEAR EXPLODED VIEW
FRONT RIGHT VIEW

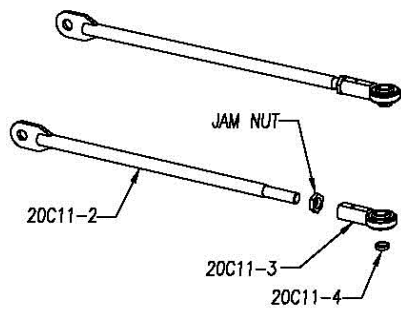

STEERING ROD

