



Quality aircraft since 1974

SERVICE LETTER June 06-2005

Issue Date

Thursday, June 09, 2005

Subject/Purpose

This Service Letter is for adding a placard beside each wing tank filler neck and for adding a fuel indicator tab to filler at wing fuel tanks. When filling each tank up to the tab, there is approximately 10 USG per tank.

Affected Models

None. As required.

Compliance Time

None.

Inspection

None.

Required Parts

Part Number	Description	Qty
20-M-42-1	Placard: <div style="border: 1px solid black; padding: 10px; text-align: center;">BOTTOM OF FUEL FILLER TAB INDICATES APP. 10 USG. SEE SERVICE LETTER 06-2005</div>	2
AN 470-AD-4-6	Solid rivet	2
20-M-42-2	Tab	2

Installation:

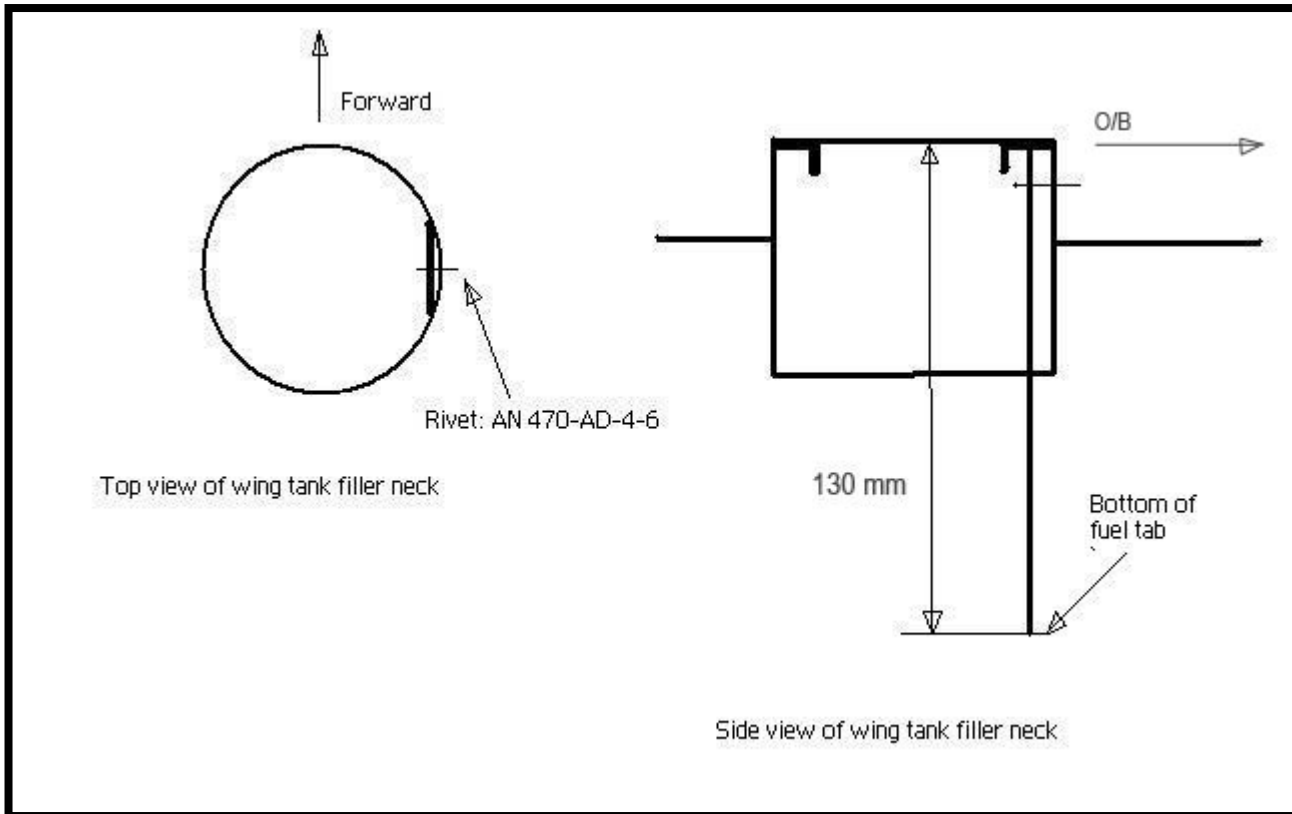

Install tab as shown in above. Install placard beside fuel filler neck. Make sure that no debris enter tanks.

Note that nylon fuel safety cap must be attached to fuel tank filler cap when filling fuel past bottom of fuel tab.

Note that fuel indicators in cabin are calibrated and placarded for full tanks, and not to fuel indicator tabs.

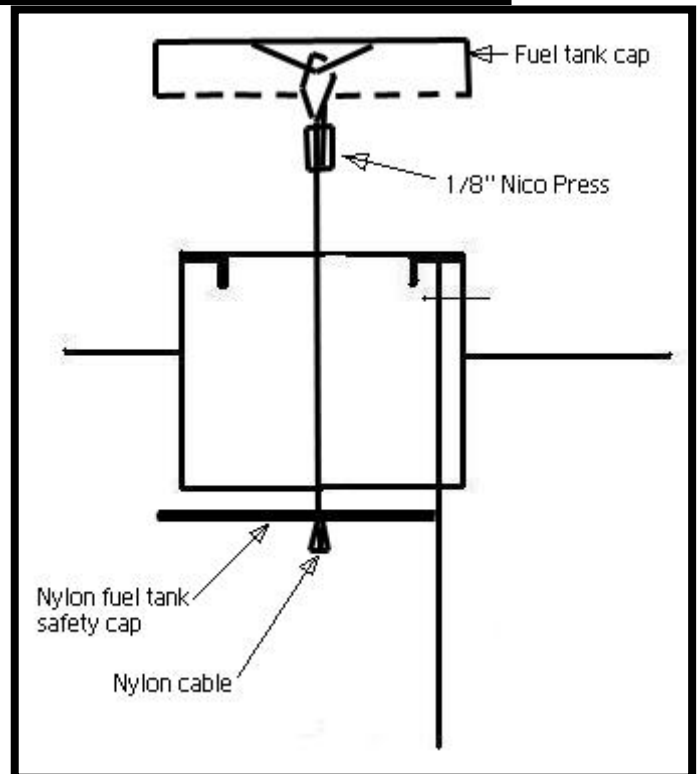

For additional information contact Zenair Ltd.

**ZENAIR LTD, HURONIA AIRPORT, MIDLAND, ONTARIO, CANADA L4R 4K8
TEL:(705) 526-2871 - FAX:(705)526-8022**